



EXPERIENCE CLEAN AIR IN STYLE

Rinnai



reddot winner 2021





LEAVES YOUR KITCHEN FRESH & CLEAN

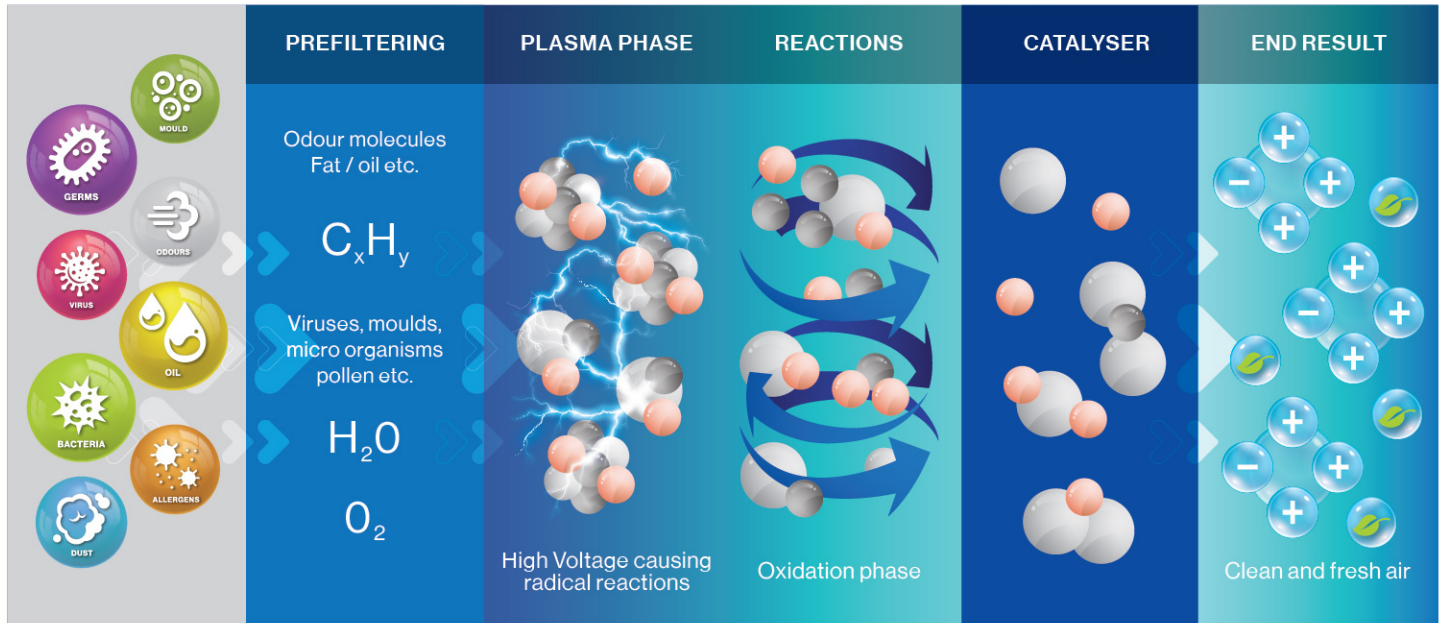

PLASMA AIR PURIFICATION TECHNOLOGY



Plasmafresh™ – Revolutionary Technology

Plasmafresh™ air purification technology effectively eradicates 98% of odours, fumes, allergens, and pollutants, while efficiently filtering grease at an impressive rate of 95.7%

With Plasmafresh, your kitchen is ensured to always remain clean and fresh.

Intelligent Purification System

Plasmafresh™ purification is a technology that uses electricity to change the composition of molecules. The plasma filter creates a safe and small electric field, which efficiently charges pollutant molecules. These charged particles are effectively deodorised by the activated carbon filter. The purified air flows back into the room, providing clean and fresh air.

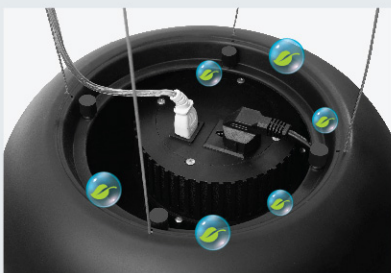

Less Maintenance vs Traditional Charcoal Filters

The activated carbon filter has a high degree of porosity and surface area. This prolongs the lifespan for at least 5 years with up to 4 hours of daily use. In contrast, traditional charcoal filters need replacement every 6 months or 1 year, depending on usage.





 PLASMA AIR PURIFICATION TECHNOLOGY



 reddot winner 2021

ISLAND SERIES



RH-D3154

- Plasma Air Purification Technology
- LED Touch Sensor Control
- Decorative LED Light
- 3 Speed settings + Booster Function
- Delay Timer
- Airflow: 650m³/h
- Remote Control (Option)

Dimension W410 x D410 x H590-2490 (mm)

RH-D3154-BKR (Black)

RH-D3154-BLR (Blue)

RH-D3154-ORR (Orange)



Touch Sensor



Recirculation



Remote Control (Option)

Remote control provides convenient access to on/off, speed adjustment, and lighting functions.

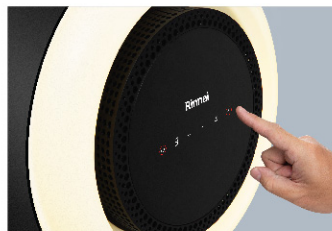

Sensor Touch Control

Touch control is extremely easy to use and indicates speed, light and delay timer.



Delay Timer

The cooker hood will switch off automatically at a preset time, so you can proceed with your meal after cooking is done. Meanwhile, the cooker hood will continue to extract the oily fumes, leaving a clean kitchen without smoke or pungent smells.



Metal Grease Filter

An essential component that filters out grease, smoke, and other airborne particles generated during cooking. This filter with magnet is easy to take apart and clean.



NEW

plasmafresh™

RH-C1059-PBR

- Powerful Turbo DC Motor
- Plasma filter to remove fumes and odor effectively
- Electronic touch control with delay stop timer
- 3 speeds settings + Booster function
- Parameter Panel with LED Stripe Decorative Light
- Parameter Panel: Water Proof (IP4)
- Oil Cup equipped
- Airflow: 1,200m3/hr

Dimension W898 x D500 x H550-1030 (mm)

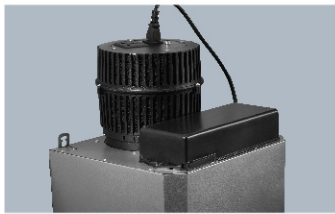
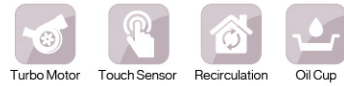

Plasmafresh™ For Cleaner Air



Frosted Black Finishing For Less Finger Prints



Water Proof Panel For Easy & Safe Maintenance

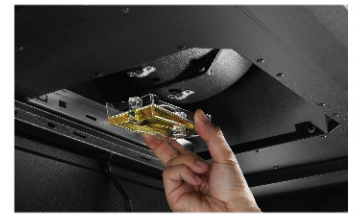

Oil Cup Equipped

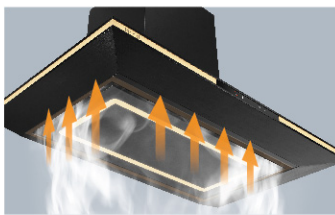

Parameter Panel For Sleek Look



Touch Control With Delay Timer



Diagonal Bottom Shape Edge For Elegant & Sleek Design

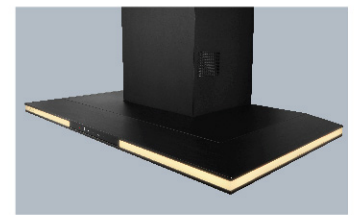

LED Strip Light For Better Ambience In Kitchen



NEW

RH-S3059-PBW

- Twin powerful motor
- Electronic touch control with delay stop timer
- 3 speeds setting
- LED decorative strip light & 2 LED lights
- Frosted Black Body for less finger prints
- Black color 5 layer Aluminium mesh filter
- Charcoal filter
- Airflow: 580m3/h

Dimension W895 x D495 x H110 (mm)

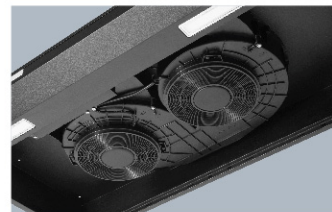

Powerful Twin Motor With High Suction



Touch Control With Delay Timer

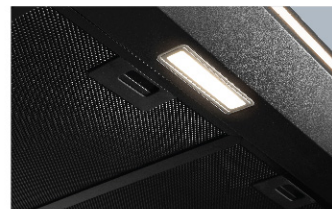

Black Colour 5 Layer Aluminium Mesh Filter

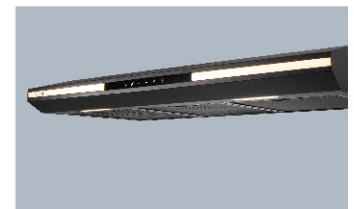

LED Strip Light For Better Ambience In Kitchen



Diagonal Front Shape For Elegant & Sleek Design



Frosted Black Finishing For Less Finger Prints

SLIMLINE SERIES



RH-S329-PBR

- Recirculation Mode • LED Light • 3 Speed Setting
- Backlit Logo • Charcoal Filter • Touch Control
- Delay Timer • Air Flow 500m³/h
- 3 Motors for uniform suction

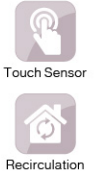

Dimension W895 x D425 x H120 (mm)



RH-S309-GBR-T

- Recirculation mode • LED Light • 3 speed setting
- Delay timer • Rectifier panel • Charcoal Filter
- Touch Control • 2 motors • Air Flow 430m³/h

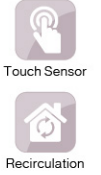

Dimension W900 x D420 x H120 (mm)



RH-S269-SSR

- Recirculation mode • LED Light • 3 speed setting
- Push Control • Charcoal Filter • 2 motors
- Air Flow 430m³/h



Dimension W895 x D425 x H120 (mm)



RH-S259-SSR-T

- Recirculation Mode • LED Light • 4 Speed Setting
- Delay Timer • Stainless Steel Oil Collector
- Rectifier Panel • Charcoal Filter • Touch Control
- Air Flow 520m³/h



Dimension W898 x D515 x H140 (mm)



Sensor Touch Control



LED Light



Magnetic Lock



Rectifier Panel



RH-S65A-SSVR

- Recirculation Mode
- 3 Speed Setting
- Charcoal Filter / LED Light
- Air Flow 400m³/h



Dimension W596 x D495 x H100 (mm)



RH-S95A-SSVR

- Recirculation Mode
- 3 Speed Setting
- Charcoal Filter / LED Light
- Air Flow 400m³/h



Dimension W896 x D495 x H100 (mm)



RH-90ER / RH-90ERi

- Stainless Steel and Metallic Silver Finishing
- Recirculation mode
- Rectifier Panel & Oil cup
- Air Flow 515m³/h

Dimension W900 x D530 x H150 (mm)

**RH-90ERi features negative ion for healthy air*

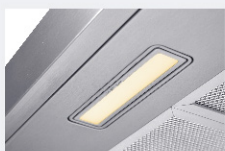

LED Lights



Mechanical Control Buttons



Enhanced Performance and Efficiency

CHIMNEY SERIES



RH-C91A-SSVR

- Powerful Turbo DC Motor • LED Touch Sensor
- LED Light Bar • 3 Speed + Booster Function
- Stainless Oil Collector • Delay Timer • Airflow 1,350m³/h
- Tempered Glass Finishing for Easy Maintenance

Dimension W898 x D500 x H574-1032 (mm)



Powerful Turbo Motor



Touch Sensor



Recirculation



Ventilation



Oil Cup

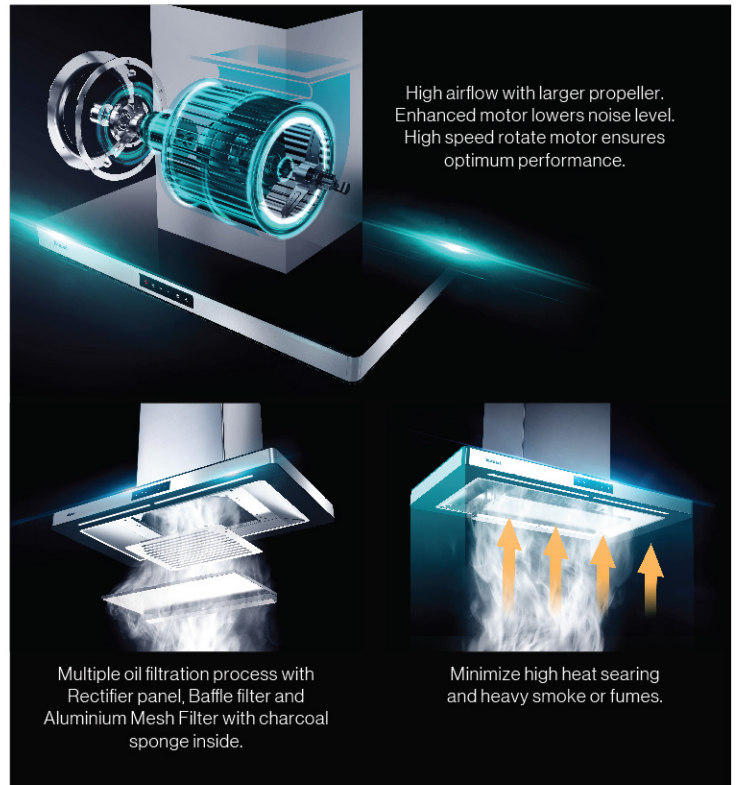

Rectifier Panel

Speeds up extraction of smoke and grease



Sleek Design

Glass surfaces on top and below, and a rounded edge, provide a polished look



Aluminium Mesh Filter

Captures particles of grease, keeping the kitchen free of oily fumes



Baffle Filter

Contains double filtration to help extract rising oil fumes and grease



NEW

RH-C2859-SSW

- Powerful Turbo DC Motor
- LED Touch Sensor
- LED Light
- Delay Timer
- 3 Speed + Booster Function
- Airflow 1,350m³/h

Dimension

W895 x D500 x H598-1078 (mm)



Powerful Turbo Motor



Touch Sensor



Recirculation



Ventilation



Oil Cup



RH-C209-GCR

- LED Touch Control
- LED Light
- Delay Timer /Oil Cup
- Charcoal Filter
- Airflow 1,100m³/h

Dimension

W898 x D460 x H479-854 (mm)



Touch Sensor



Recirculation



Oil Cup



RH-C249-SSR

- LED Touch Control
- LED Light
- Delay Timer /Oil Cup
- Charcoal Filter
- Airflow 1,100m³/h

Dimension

W900 x D500 x H490-970 (mm)



Touch Sensor



Recirculation



Oil Cup

RH-D3154

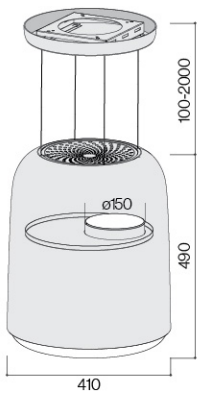

RH-C1059-PBR

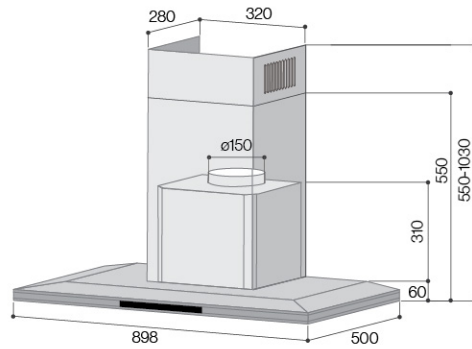

RH-C91A-SSVR

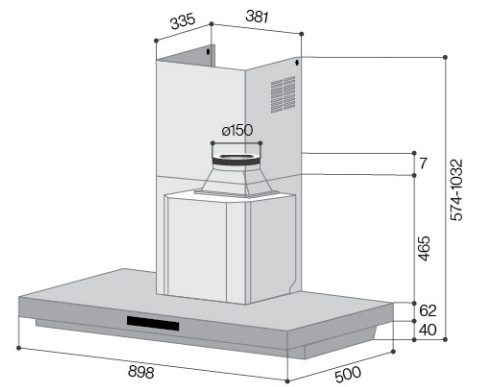

RH-C2859-SSW

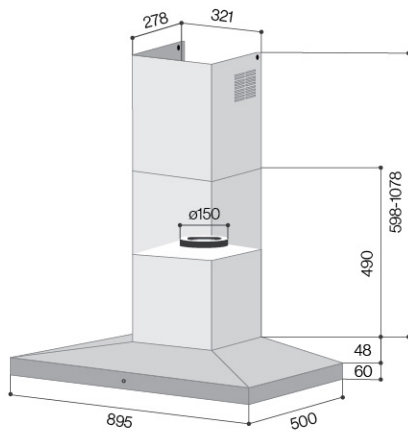

RH-C209-GCR

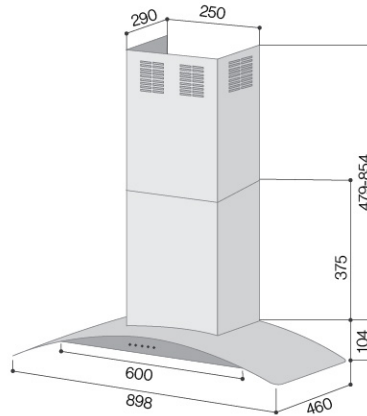

RH-C249-SSR

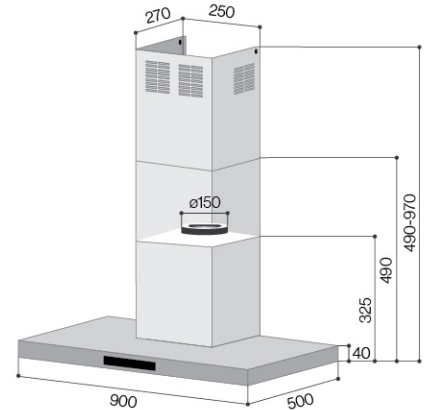

RH-S3059-PBW

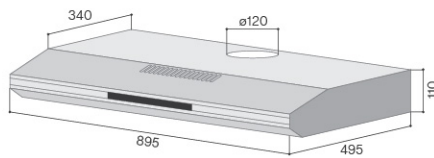

RH-S259-SSR-T

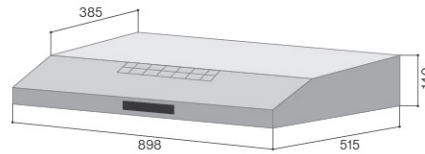

RH-S95A-SSVR / RH-S65A-SSVR*

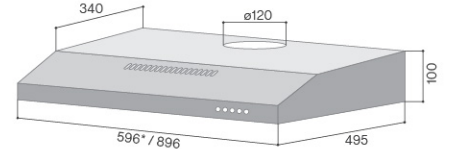

RH-S329-PBR / RH-S269-SSR

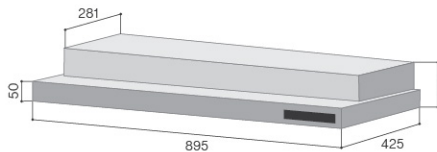

RH-S309-GBR-T

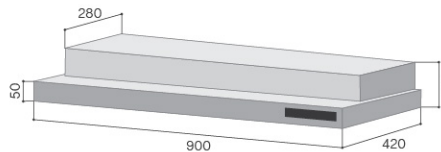

RH-90ER / RH-90ERi

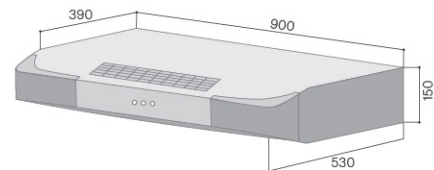

Scan for more details



Find the Perfect Fit for Your Cooker Hood:
Easy Spare Parts Shopping Online!
www.rinnai.sg



RINNAI HOLDINGS (PACIFIC) PTE LTD

61 Ubi Road 1 #02-20 & 21, Oxley Bizhub Singapore 408727

Tel 6748-9011 Fax 6745-9240

Website www.rinnai.sg

rinnaiholdingspacific

rinnai_sg

Rinnai SG

Scan for more details

